

2

1

TOP VIEW

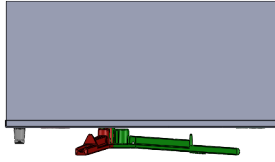

NOTES:

1. BOX AND COVER CONSTRUCTION - GALV SHEET STEEL (12GA).
2. FINISH: POWDERCOAT GRAY ENAMEL.
3. BUS BARS- COPPER 98% CONDUCTIVITY.
4. TERMINALS INCLUDED - SEE CHART FOR # OF SETS.
5. TOP HINGED COVER WRAPS AROUND EDGES ON 3 SIDES, HINGE ON RIGHT SIDE IS STANDARD, BOTTOM COVER IS A FLAT SCREW COVER.
6. NO VENTING UNLESS SPECIFICALLY REQUESTED.
7. LOCKABLE IN "OFF" POSITION STANDARD - LOCKABLE IN "ON" AVAILABLE BY REQUEST.
8. ISOLATED NEUTRAL BUS WITH REMOVABLE LINK IN CENTER AVAILABLE BY REQUEST.
9. PADMOUNT AVAILABLE BY REQUEST.

B

OPTIONAL VIEWING WINDOW (NON STANDARD)

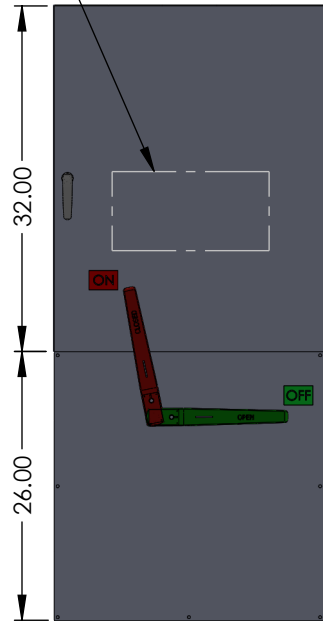

FRONT COVERED VIEW

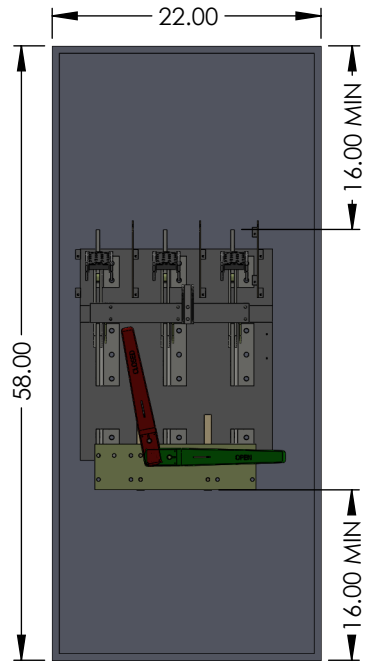

FRONT OPENED VIEW

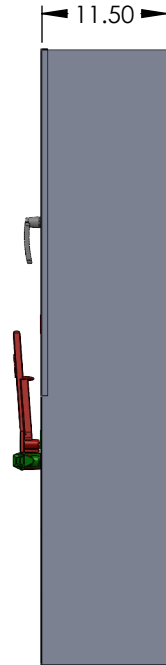

SIDE VIEW

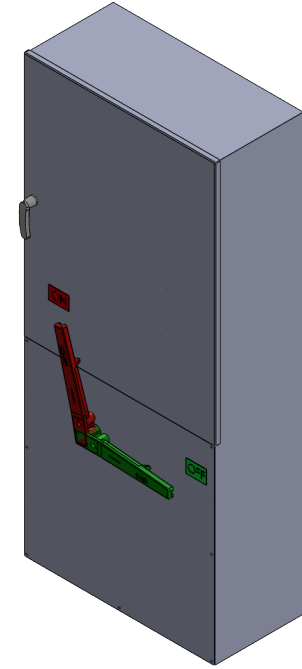

B

PART #	AMPS	MAX VOLTS	FEED	SWITCH	LUGS
400BPS-T	400A	600V	TOP	J365WOL	1 SET 600MCM
400BPS-B	400A	600V	BOTTOM	JB365WOL	1 SET 600MCM
600BPS-T	600A	600V	TOP	J366WOL	2 SETS 600MCM
600BPS-B	600A	600V	BOTTOM	JB366WOL	2 SETS 600MCM
800BPS-T	800A	600V	TOP	L367-A	2 SETS 600MCM
800BPS-B	800A	600V	BOTTOM	LB367-A	2 SETS 600MCM

A

A

DRAWN BY	NAME N. BOSETTI	DATE 2/11/2025		MAT'L: 12 GAUGE GALV STEEL	DRAWING TITLE: 400A-800A ENCLOSED BPS	DESCRIPTION: NEMA 1 ENCLOSED BOLTED PRESSURE SWITCH 3P/3W RATINGS: 400A-800A 200K AIC MAX
REVIEWED BY				FINISH: GRAY POWDER COAT ANSI 61	PART #: XXXBPS-X	
PROPRIETARY AND CONFIDENTIAL THE INFORMATION CONTAINED IN THIS DRAWING IS THE SOLE PROPERTY OF NAV-TECH INC. ANY REPRODUCTION IN PART OR AS A WHOLE WITHOUT THE WRITTEN PERMISSION OF NAV-TECH INC. IS PROHIBITED.			155 MARCUS BLVD HAUPPAUGE, NEW YORK 11788 PH: (718) 257-2111 FAX: (718) 257-2626	WEIGHT: ALL DIMENSIONS ARE NOMINAL UNLESS EXPLICITLY STATED OTHERWISE	DO NOT SCALE DRAWING	SCALE: 1:20 SIZE A SHEET 1 OF 1 REV. 1

2

1